

ベアリング用同心止め輪 軸用

- ベアリングの位置決めや、コロ受けに使用されます。
- 内径外径の中心が同じで、軸用は内径基準となります。

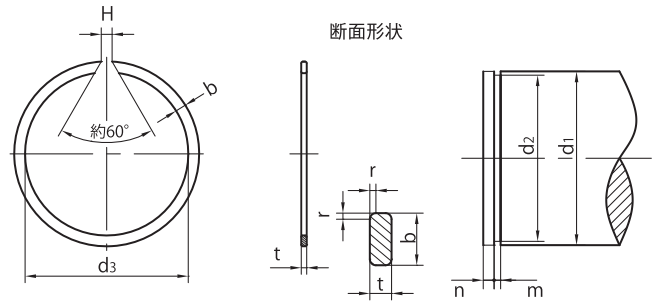

WR

単位 mm

呼び	止め輪					適用する軸				
	内径		厚さ	板幅	口幅	軸径	溝底径		溝幅	
	d3		t ±0.06	b ±0.08	H	d1	d2		m +0.14 0	
	基準寸法	許容差					基準寸法	許容差		
20	18.7	0 -0.5	1.2	1.75	2.0	20	19.2	0 -0.21	1.36	
21	19.7		1.2	1.75	2.0	21	20.2		1.36	
22	20.7		1.2	1.75	2.0	22	21.2		1.36	
23	21.7		1.2	1.75	2.0	23	22.2		1.36	
24	22.5		1.2	1.75	2.0	24	23.0		1.36	
25	23.5		1.2	1.75	2.0	25	24.0		1.36	
26	24.5		1.2	1.75	3.0	26	25.0		1.36	
28	26.5		1.5	2.30	3.0	28	27.0		1.66	
29	27.5		1.5	2.30	3.0	29	28.0		1.66	
30	28.5		1.5	2.30	3.0	30	29.0		1.66	
32	30.2	0 -1.0	1.5	2.30	3.0	32	30.8	0 -0.25	1.66	
35	33.2		1.5	2.30	3.0	35	33.8		1.66	
37	35.2		1.5	2.30	3.0	37	35.8		1.66	
38	36.2		1.5	2.30	3.0	38	36.8		1.66	
40	37.8		1.5	2.30	3.0	40	38.5		1.66	
42	39.8		1.5	2.30	3.0	42	40.5		1.66	
43	40.8		1.5	2.30	3.0	43	41.5		1.66	
45	42.8		1.5	2.30	3.0	45	43.5		1.66	
47	44.8		1.5	2.30	4.0	47	45.5		1.66	
48	45.8		1.5	2.30	4.0	48	46.5		1.66	
50	47.8	1.5	2.30	4.0	50	48.5	1.66			
52	49.8	1.5	2.30	4.0	52	50.5	0 -0.30	1.66		
55	52.6	1.5	2.30	4.0	55	53.5		1.66		
58	55.6	1.5	2.30	4.0	58	56.5		1.66		
60	57.6	1.5	2.30	4.0	60	58.5		1.66		
61	58.6	1.5	2.30	4.0	61	59.5		1.66		
62	59.6	1.5	2.30	4.0	62	60.5		1.66		

●材質：SWRH57～82 A又はB（硬鋼線材）を用いた硬鋼線又は相当材とする

●硬さ：40～50HRC

●表面処理：黒染 ●受注生産

ベアリング用同心止め輪 軸用

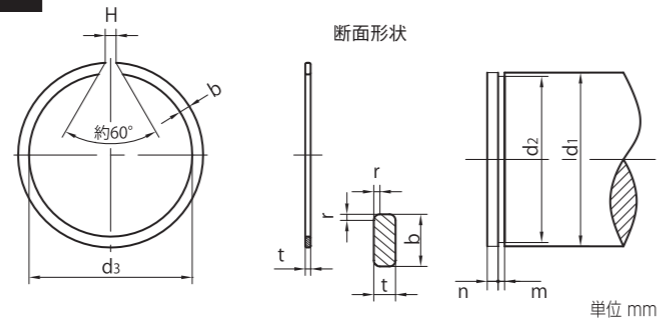

WR

呼び	止め輪				適用する軸					
	内径		厚さ	板幅	口幅	軸径	溝底径		溝幅	
	d3		t ±0.06	b ±0.08	H	d1	d2		m +0.14 0	
	基準寸法	許容差					基準寸法	許容差		
63	60.6	0 -1.0	1.5	2.30	4.0	63	61.5	0 -0.30	1.66	
64	61.6		1.5	2.30	4.0	64	62.5		1.66	
65	62.6		1.5	2.30	4.0	65	63.5		1.66	
68	65.4		2.0	2.80	4.0	68	66.2		2.16	
70	67.4		2.0	2.80	5.0	70	68.5		2.16	
72	69.4		2.0	2.80	5.0	72	70.2		2.16	
73	70.4		2.0	2.80	5.0	73	71.2		2.16	
75	72.4		2.0	2.80	5.0	75	73.2		2.16	
80	77.4		2.0	2.80	5.0	80	78.2		2.16	
85	82.0		2.5	3.40	5.0	85	83.0		0 -0.35	2.66
90	87.0		2.5	3.40	6.0	90	88.0			2.66
95	92.0		2.5	3.40	6.0	95	93.0			2.66
100	97.0		2.5	3.40	6.0	100	98.0		0 -0.54	2.66
105	101.7		2.5	3.40	6.0	105	102.7			2.66
110	106.6		2.5	3.40	6.0	110	107.7			2.66
115	111.6	2.5	3.40	6.0	115	112.7	0 -0.63	2.66		
120	116.5	2.5	3.40	7.0	120	117.7		2.66		
125	121.4	2.5	3.40	7.0	125	122.7		2.66		
130	126.3	0 -1.5	2.5	3.40	7.0	130	127.7	0 -0.68	2.66	
135	131.0		2.5	4.00	7.0	135	132.4		2.66	
140	135.9		2.5	4.00	7.0	140	137.4		2.66	
145	140.9		2.5	4.00	7.0	145	142.4		2.66	
150	145.8		2.5	4.00	8.0	150	147.4		2.66	
155	150.8		2.5	4.00	8.0	155	152.4		2.66	
160	155.7		2.5	4.00	8.0	160	157.4		2.66	
165	160.7		2.5	4.00	8.0	165	162.4		2.66	
170	165.6		2.5	4.00	8.0	170	167.4		2.66	
175	170.6		2.5	4.00	8.0	175	172.4		2.66	
180	175.2		3.0	5.00	8.0	180	177.0		3.16	
185	180.1		3.0	5.00	8.0	185	182.0		3.16	
190	185.1		3.0	5.00	8.0	190	187.0		3.16	
195	190.1		3.0	5.00	8.0	195	192.0		3.16	

●材質：SWRH57～82 A又はB（硬鋼線材）を用いた硬鋼線又は相当材とする ●硬さ：40～50HRC
●表面处理：黒染 ●受注生産

ベアリング用同心止め輪 軸用

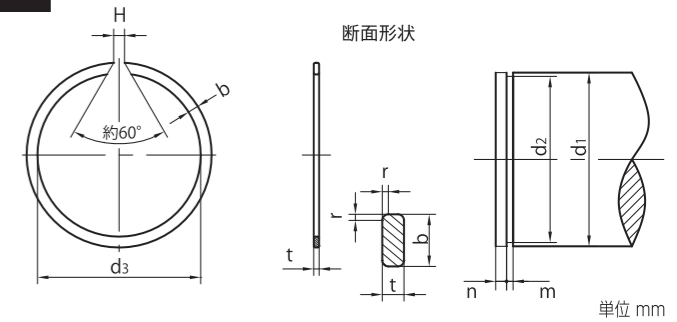

WR

呼び	止め輪				適用する軸					
	内径		厚さ	板幅	口幅	軸径	溝底径		溝幅	
	d3		t ±0.06	b ±0.08	H	d1	d2		m +0.14 0	
	基準寸法	許容差					基準寸法	許容差		
200	195.0	0 -2.0	3.0	5.00	8.0	200	197.0	0 -0.68	3.16	
210	204.9		3.0	5.00	8.0	210	207.0		3.16	
220	214.8		3.0	5.00	8.0	220	217.0		3.16	
225	219.8		3.0	5.00	8.0	225	222.0		3.16	
230	224.7		3.0	5.00	8.0	230	227.0		3.16	
240	234.6		3.0	5.00	8.0	240	237.0		3.16	
250	244.6		3.0	5.00	8.0	250	247.0		3.16	
260	252.4		4.0	7.50	10.0	260	255.0		0 -0.73	4.16
265	257.4		4.0	7.50	10.0	265	260.0			4.16
270	262.3		4.0	7.50	10.0	270	265.0			4.16
280	272.2		4.0	7.50	10.0	280	275.0		4.16	
285	277.2		4.0	7.50	10.0	285	280.0		4.16	
290	282.1		4.0	7.50	10.0	290	285.0		4.16	
300	292.1		4.0	7.50	10.0	300	295.0		4.16	
305	297.1		4.0	7.50	10.0	305	300.0		4.16	
310	302.0	4.0	7.50	10.0	310	305.0	0 -0.73	4.16		
320	311.9	4.0	7.50	10.0	320	315.0		4.16		
330	321.7	4.0	7.50	10.0	330	325.0		4.16		
340	331.6	4.0	7.50	10.0	340	335.0		4.16		
350	341.5	4.0	7.50	10.0	350	345.0		4.16		
360	351.4	4.0	7.50	10.0	360	355.0		4.16		
370	361.4	4.0	7.50	10.0	370	365.0		4.16		
380	371.3	4.0	7.50	10.0	380	375.0		4.16		
390	381.2	4.0	7.50	10.0	390	385.0		4.16		
400	391.2	4.0	7.50	10.0	400	395.0		4.16		

●材質：SWRH57～82 A又はB（硬鋼線材）を用いた硬鋼線又は相当材とする ●硬さ：40～50HRC
●表面处理：黒染 ●受注生産